

AOYUE[®] 936A/ 936

Temperature Controlled Soldering Station

Instruction Manual

Thank you for purchasing the Aoyue 936A / 936
temperature controlled soldering station.
Please read the manual before using the unit.
Keep manual in accessible place for future reference.

Manufacturer:
AOYUE TONGYI ELECTRONIC EQUIPMENT FACTORY
Jishui Industrial Zone, Nantou, Zhongshan City,
Guangdong Province, P.R.China
<http://www.aoyue.com>

REPLACEMENT SOLDERING TIPS

Conical Type

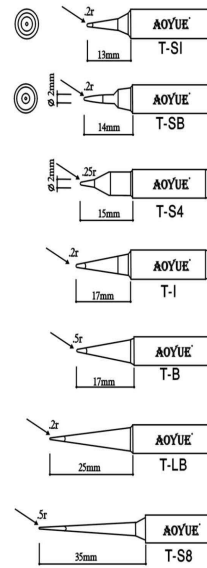

Sharp-Bent Type

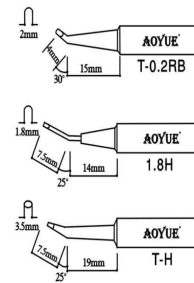

Blade Type

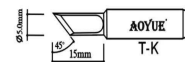

Bevel Type

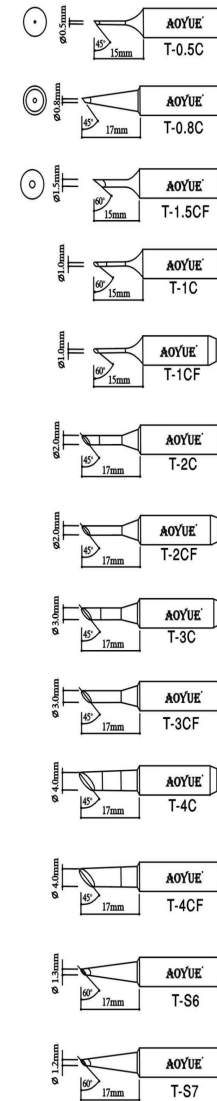

Chisel Type

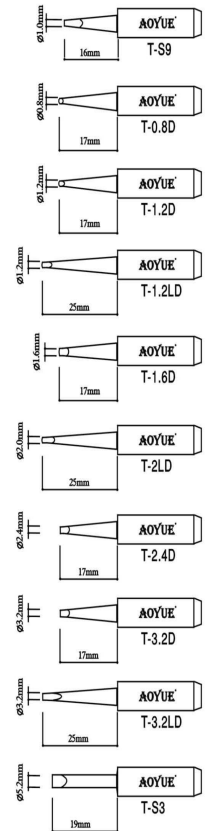

Slot Type

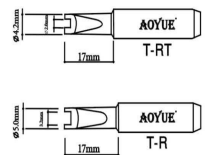

PARTS LIST

Soldering Iron Stand

#	Part Number	Description
1	20090726303	Iron Stand
2	200726302	Heat Protector
3	30100417	Aluminum Ring
4	20051304	M4 Nut
5	200726303	Plate
6	30090303	14x3 Rubber Foot
7	2005334*4	4x4 Screw
8	2005334*6	4x6 Screw
9	30090302	14x13 Rubber Foot

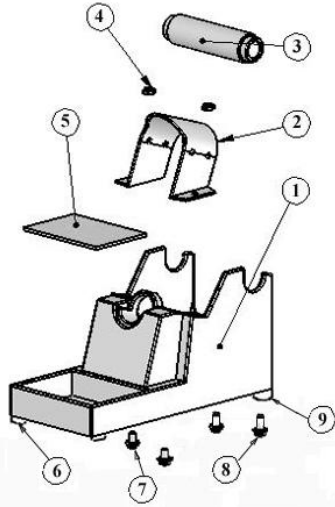

Soldering Iron

#	Part Number	Description
1	200606	Copper Nut
2	20080309	Tip Enclosure
3	T-I	Solder Tip
4	20080307	Tip Lock
5	3011936	Plastic Nut
6	201093601	Ground Spring

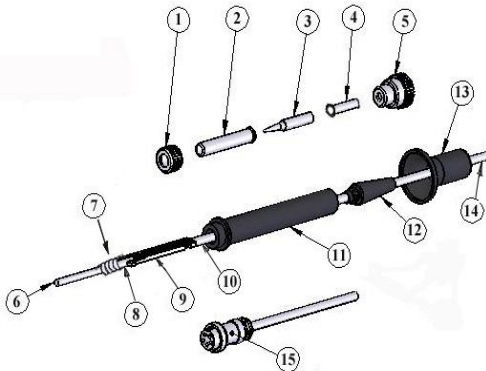

#	Part Number	Description	#	Part Number	Description
7	C008	936A HE	11	30125S	936A Plastic Handle
	C001	936 HE		30124S	936 Plastic Handle
8	20070203	Cross Chip	12	30091001	Wire Holder
9	10076936	Support Board	13	30090901	Handle Protector
10	20070204	Securing Chip	14	10110502	Wire Cord
			15	10270205	5-pin receptacle

TABLE OF CONTENTS

Package content	4
Name of parts	4
Care and Safety Precautions	5
Specification	6
Assembly and Usage	7
Soldering Tip care and Maintenance	8
Tip temperature	
Cleaning	
When not in use	
Tip calibration	
Disassembling the hand piece	10
Testing the heating element	11
Replacing the heating element	12
Troubleshooting connections	13-15
Replacing soldering iron cord	16
Reassembling the hand piece	17
Changing of fuse	18
Basic troubleshooting Guidelines	20
Parts List	21-22
Replacement Soldering Tips	23

PACKAGE CONTENT

Please check if the listed parts below are included in the package:

Aoyue 936A

936A Main Station	1 unit
Soldering Iron	1 pc.
Soldering Iron Stand	1 pc.
(including Sponge)	1 pc.
Instruction Manual	1 pc.
Power Cord	1 pc.

Aoyue 936

936 Main Station	1 unit
Soldering Iron	1 pc.
Soldering Iron Stand	1 pc.
(including Sponge)	1 pc.
Instruction Manual	1 pc.
Power Cord	1 pc.

NAME OF PARTS

Main Station

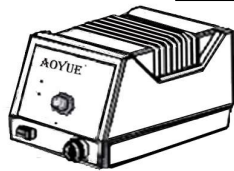

Soldering Iron

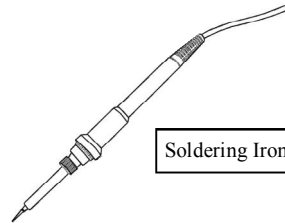

Power cord

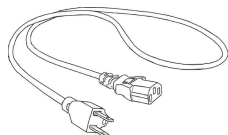

Soldering Iron stand

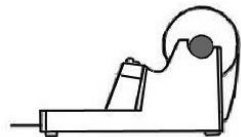

PARTS LIST

Main Station

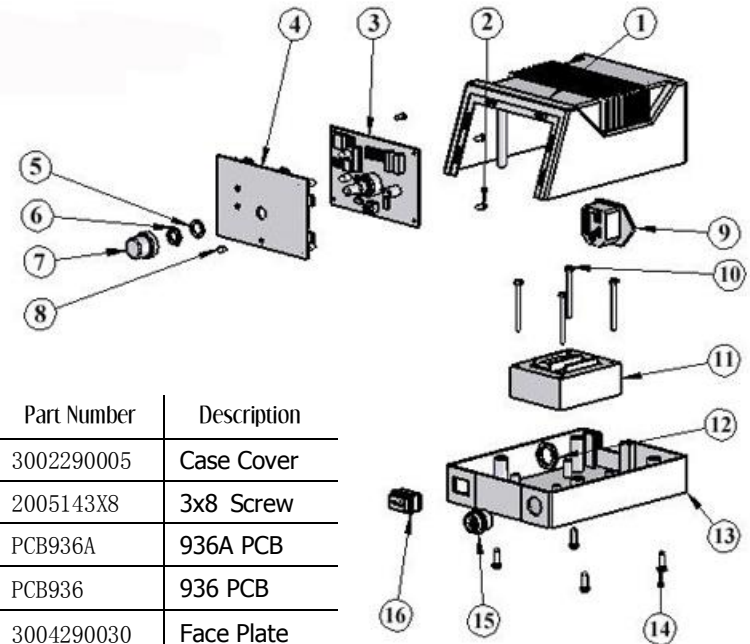

#	Part Number	Description
1	3002290005	Case Cover
2	2005143X8	3x8 Screw
3	PCB936A	936A PCB
	PCB936	936 PCB
4	3004290030	Face Plate
5	20051009	M9 Medium
6	20051309	M9 Nut
7	3005936	Knob
8	30090301	Rubber Stop
9	10090405	Fuse Holder with Fuse
10	2005154x60	4x60 Screw

#	Part Number	Description
11	10039. 220V	936A transformer 220v
	10039. 110V	936A transformer 110v
	10037. 220V	936 transformer 220v
	10037. 110V	936 transformer 110v
12	960101. 1	Receptacle Nut
13	3002290006	Case Bottom
14	2005154x12	4x12 Screw
15	960101	Receptacle Holder
16	101020201	Power Switch

BASIC TROUBLESHOOTING GUIDE

PROBLEM 3: SOLDERING IRON TEMPERATURE IS INTERMITTENT

Description: *Main power LED lights up and so does the heater LED but soldering iron temperature rises and falls uncontrollably.*

SOLUTION:

- ◆ Soldering iron plug may be loose from the receptacle unplug the soldering iron and reattach.
- ◆ Soldering iron cord may be damaged or loose and needs to be replaced or repaired. See trouble shooting soldering iron cords section of this manual.

PROBLEM 4: SOLDER WOULD NOT STICK TO THE SOLDERING TIP

Description: *Soldering iron is able to quickly melt solder but cannot cause the solder to attach to the tip.*

SOLUTION:

- ◆ Soldering iron tip may already be too dirty or oxidized . Please see our solder tip maintenance guide on how to clean soldering tips.
- ◆ Temperature could be set too high causing solder to quickly burn away, Please adjust to a more suitable lower temperature range.

PROBLEM 5: SOLDERING IRON DOES NOT PRODUCE ENOUGH HEAT

Description: *Soldering iron cannot melt solder fast enough, or actual temperature does not reach the desired set temperature.*

SOLUTION:

- ◆ The system may need to be recalibrated please see [*steps in calibrating the tip temperature*](#) on page 9 of this manual.
- ◆ Soldering iron tip may already be too dirty or oxidized . Please see our solder tip maintenance guide on how to clean soldering tips.

CARE and SAFETY PRECAUTIONS



CAUTION: Misuse may cause injury and physical damage. For your own safety, be sure to comply with the following precaution.

- Temperature may reach a high of 480°C when turned on.
 - Do not use near flammable gases, paper and other materials.
 - Do not touch heated parts, can cause severe burns.
 - Do not touch metallic parts near the Tip.
- Thermal Protector
 - Unit is equipped auto shut-off ability when temperature gets too high and automatically turns on when temperature dropped to a safe level.
- Handle with Care
 - Never drop or sharply jolt the unit.
 - Contains delicate parts that may break if unit is dropped.
- Disconnect plug when not to be used for a long period of time.
 - Turn off power during breaks.
- Use only genuine replacement parts.
 - Turn-off power and let unit cool before replacing parts.
- Soldering process produces smoke, make sure work area is well ventilated.
- Do not modify unit
- Never touch the element or tip of the soldering iron. They are very hot (about 400°C) and will give you a nasty burn.
- Take great care to avoid touching the mains flex with the tip of the iron. The iron should have a heatproof flex for extra protection. An ordinary plastic flex will melt immediately if touched by a hot iron and there is a serious risk of burns and electric shock.
- Always return the soldering iron to its stand when not in use.
- Work in a well-ventilated area. The smoke formed as you melt solder is mostly from the flux and is quite irritating. Avoid breathing it by keeping your head on the side and not directly above of your work.
- Wash your hands after using solder. Solder may contain lead which is a poisonous metal.

SPECIFICATION

Model#	936A	936
Power Consumption	60W	35W
Fuse	1A	0.5A
MAIN STATION		
Output Voltage	24V	24V
Temperature Range	200—480 °C 392—896 °F	200—480 °C 392—896 °F
Dimension	110(w)×93(l) ×168(h) mm	110(w)×93(l) ×168(h) mm
SOLDERING IRON		
Power Consumption	24V—60W	24V—60W
Tip to Ground Resistance	Less than 2 Ohm	Less than 2 Ohm
Tip to Ground Potential	Less than 2 Ohm	Less than 2 Ohm
Heating Element	Japan-made Ceramic Heating Element	Ceramic Heating Element
Power Cord	1.1 meters	1.1 meters
Length	1.2 meters	1.2 meters
Weight	108 grams	100 grams

Design and specification might change without prior notice.

BASIC TROUBLESHOOTING GUIDE



WARNING: To avoid personal injury or equipment damage, disconnect power cords before making any servicing to the equipment, or unless instructed otherwise in the troubleshooting procedures.

PROBLEM 1: THE UNIT HAS NO POWER /MAIN POWER LED DOES NOT LIGHT UP

1. Check if the unit is switched ON.
2. Check the fuse. Replace with the same type of fuse if blown.
3. Check the power cord and make sure there are no disconnections.
4. Verify that the unit is properly connected to the power source.

Additional precautions :

- ◆ Check internal circuitry for shorts that may cause the blown fuse. See "*Troubleshooting Connections*" on page 13-15.
- ◆ Check for tangles of wires in the heating element causing it to short. See "*Troubleshooting Connections*" on page 13-15.

PROBLEM 2: SOLDERING IRON DOES NOT RISE IN TEMPERATURE

Description: Main power LED lights up and so does the heater LED but soldering iron temperature is relative low and is not heating up.

SOLUTION:

Soldering iron cord may be damaged and needs to be replaced or repaired. See "*Troubleshooting Connections*" on page 13-15 of this manual.

Heating element may be damaged and needs to be replaced see "*Testing the Heating Element*" on page 11 and "*Replacing the Heating Element*" on page 12 on this manual.

CHANGING THE FUSE

Checking the fuse:

The Fuse can be found at the back of the unit, it is incorporated into the AC power receptacle. If fuse is blown replace with same type fuse only.

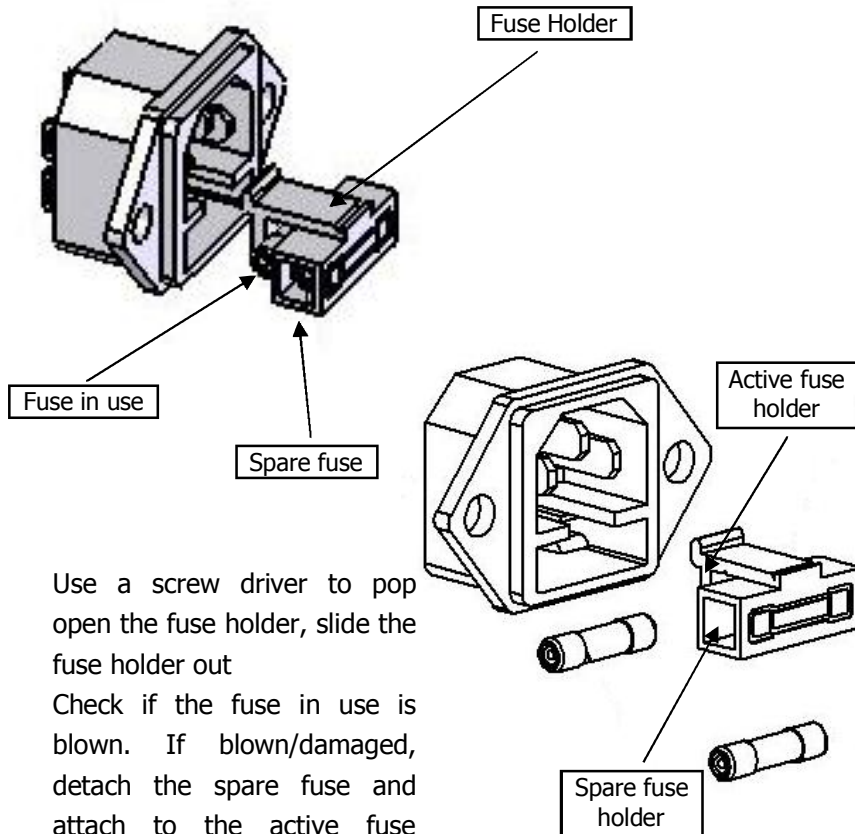

1. Use a screw driver to pop open the fuse holder, slide the fuse holder out
2. Check if the fuse in use is blown. If blown/damaged, detach the spare fuse and attach to the active fuse holder.) .
3. Reattach the fuse holder.

ASSEMBLY and USAGE

I. SOLDERING IRON HOLDER

1. Install solder wire to the solder iron holder. (Fig. 1)
2. Dampen the cleaning sponge with water, squeeze it dry and place it in its base. (Fig. 2)

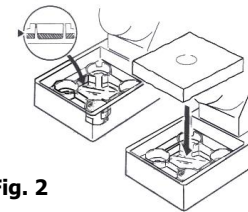

Fig. 2

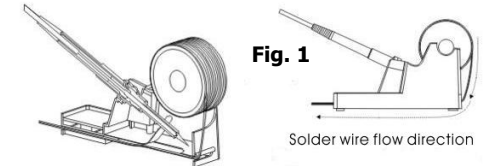

Fig. 1

⚠ Failure to dampen sponge might damage the soldering tip.

II. SOLDERING IRON

1. Attach the soldering iron to the receptacle connector at the bottom right area of the main unit.
2. Place soldering iron to the soldering iron stand as shown in Fig. 1
3. Plug the power cord into a receptacle with ground.

⚠ Soldering iron must be placed in the iron holder when not in use.

III. MAIN UNIT

1. Turn on unit and
2. When the heater lamp blinks on and off then it means that the tip temperature has reached the set temperature and is ready for use.

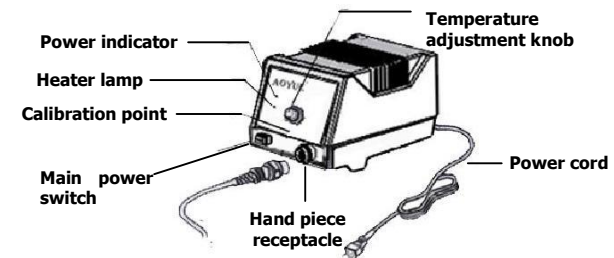

SOLDER TIP CARE and MAINTENANCE

● Tip Temperature

If the tip temperature is too high, it decreases the life of the tip. So we suggest you to use the lowest *possible* tip temperature when soldering. This not only prolong life of the tip, it also quickens heat recovery and decreases harm to sensitive components.

● Cleaning

The soldering iron tip should be cleaned after use by wiping it on the damp sponge found in the soldering iron stand, this is to get rid of burnt solder or fluxes that causes oxidation on the tip. Regular cleaning is also needed when tips are used for prolonged period of time (remove tip from soldering iron and clean it once a week). The solder tips are chrome electroplated on the surface and should be bright silver with no flux residue or solder on it.

⚠ Remember to tin the tip after cleaning in preparation for the next use.

● When Not in Use

If a soldering iron does not have a thin consistent layer or solder over the entire surface, the tip has not been properly tinned. When you are not using your iron, make sure you leave a large lump of solder on the tip. This maintains the tinning on the tip, and the tip will last much longer. Many technicians mistakenly clean the tip before they put the iron into the holder. Leave the solder on the tip to protect it.

REASSEMBLY OF HAND PIECE

After test or replacement of heating elements are done follow the following steps to reassemble the hand piece:

1. Slide in hand piece PCB into the main handle. Be sure to secure the PCB in the notch at the mouth of the main handle.
2. Attach the front module "5" to the main handle.
3. Slide in the Tip holder "4". Make sure the smaller end is inserted first as seen in the illustration below.
4. Insert the soldering iron tip "3" as seen below.
5. Secure the tip by inserting the tip enclosure "2" and nut "1" securely.
6. Reattach the hand piece plug "15" to the receptacle at the main station.
7. Recalibrate the soldering iron, see guide on tip care and maintenance section of this manual.

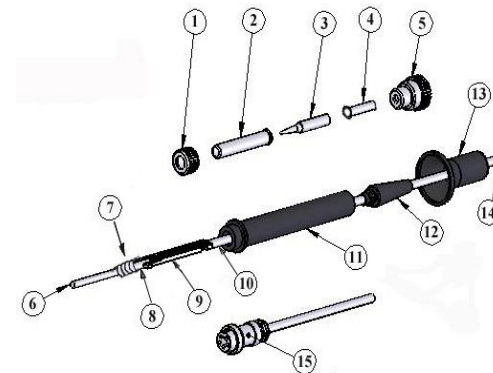

REPLACING SOLDERING IRON CORD

When cord is proven to be faulty follow the steps to replace the cord:

1. Follow the steps in disassembling the hand piece.
2. Write down or make a brief illustration of wire configuration in the PCB.

Note : Different models have different configurations it is critical to have proper wire configurations clearly noted before proceeding to the next step. (See proper connections table for reference)

3. Unsolder the wires connecting the hand piece PCB and cord together.
4. Unattached the (white wire for 963 , black wire for 936A) connecting the cord and grounding spring together.
5. Detach the PCB from the cord by releasing the metal grips located at the bottom of the PCB .
6. Slide out the main handle , soft grip pad and tail end of the hand piece.
7. Insert the tail end and soft grip pad into the new cord.
8. Insert the new cord through the main handle.
9. Solder the wires back into the PCB, using the proper configurations.
10. Reattach the wires (white wire for 963 , black wire for 936A) from the new cord to the grounding spring.
11. Bend the metal on the bottom end of the PCB to grip the cord firmly.
12. Follow "Reassembly of hand piece" procedure to complete the process.

SOLDER TIP CARE and MAINTENANCE

● **STEPS in Checking, Cleaning and Tinning the Tip**

⚠ Never use file or sharp rough objects in removing oxidation of the tip the tip.

1. Set temperature to 250° C (482° F)
2. After real temperature reaches the set temperature, use a damp sponge to clean the tip and check for damages.
3. If the tip has oxidation, apply solder and wipe using the damp sponge, repeat these steps until oxidation is removed.
4. After cleaning, coat tip with a thin layer of solder and set it aside ready for the next usage.
5. If the tip shows disfiguration or has rust on it. Change the tip.

⚠ Temperature calibration must be done every time you change the solder tip or change the heating element.

● **STEPS in Calibrating the Tip Temperature**

1. Plug in station and turn it on.
2. Set temperature to 400° C (750° F)
3. Wait for Heater LED to light up.
4. Use an external sensor and place it on the solder tip.
5. Take off the rubber stop in the CAL point. Use a screwdriver, one that fits the CAL hole, to adjust the CAL point.
Turn clockwise - To increase temperature
Counterclockwise - To decrease temperature
6. Adjust until the external sensor reads 400° C (750° F).

DISASSEMBLING THE HAND PIECE

The hand piece may be disassembled for trouble shooting and repair:

1. Turn off main station and unplug from power source.
2. Detach the Soldering Iron Receptacle ("15" as shown in the figure below) from the main unit.
3. Turn the Copper Nut, ("1" as shown in the figure below) counter clockwise to loosen it.
4. Pull out the Tip Enclosure ("2" as shown in the figure below), the Solder Tip ("3" as shown in the figure below), and the Tip Lock ("4" as shown in the figure below).
5. Turn the Plastic Nut ("5" as shown in the figure below) counter clockwise to release it from the main body.
6. Push out the Heating Element ("6" as shown in the figure below) via the Wire Cord ("14" as shown in the figure below).

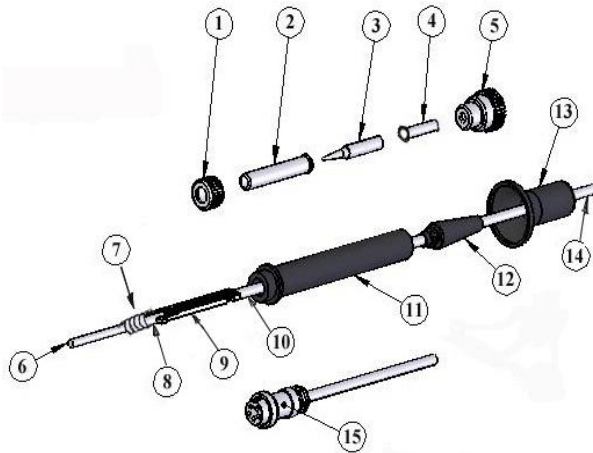

TROUBLESHOOTING CONNECTIONS

Additional notes:

Proper connections table:

For 936A:

PIN	CORD COLOR	CORD COLOR	Heating element
1	RED	RED	RED
2	BLUE	BLUE	RED
3	BLACK	BLACK	SPRING
4	GREEN	GREEN	BLUE
5	WHITE	WHITE	BLUE

For 936:

PIN	CORD COLOR	CORD COLOR	Heating element
1	RED	RED	RED
2	YELLOW	YELLOW	RED
3	WHITE	WHITE	SPRING
4	BLUE	BLUE	BLUE
5	BLACK	BLACK	WHITE (coarse)

TROUBLESHOOTING CONNECTIONS

Follow the following direction to test for hand piece cord faults:

Test 1: Rendering physical strain to the cord

1. Turn on the unit.
2. Set temperature to 480 °C.
3. Bend and straiten the entire length of the cord bit by bit. The heater lamp should always be lit while doing so. If the heater lamp becomes intermittent the cord is faulty and should be replaced.

Note: the Heater lamp will blink if the temperature of the soldering iron tip has reached the set temperature i.e. 480 C. this is not an indication of a faulty cord.

Test 2: Resistance test

1. Follow the steps in disassembling the hand piece .
2. Test for continuity between the following pins and colored wires at the hand piece PCB, all tests should register 0 to 2 Ω.
3. If any of the above mentioned combination does not register 0 Ω the cord is faulty and should be replaced.
4. See our "replacing the soldering iron cord"guide.

For 936A:

Pin 1 & Red wire	Pin 2 & BLUE wire
Pins 3 & BLACK wire	Pin 4 & GREENwire
Pin 5 & WHITE wire	

For 936:

Pin 1 & RED wire	Pin 2 & YELLOW wire
Pins 3 & WHITE wire	Pin 4 & BLUE wire
Pin 5 & BLACK wire	

TESTING THE HEATING ELEMENT

To test if the heating element is in working condition:

Cool down assembly to room temperature before continuing the tests below:

1. Follow "*disassembling the hand piece*"guide.
2. Do the following tests on the hand piece PCB board:
 - ◆ Resistance value of heating element (RED) 2.5 — 3.5 Ω
 - ◆ Resistance value of sensor (blue) 43 — 58 Ω

After testing check results with the following:

- ◆ If the resistance value is not as stated above replace the heating element.
- ◆ If a 0 Ω or infinite resistances are measured check for shorts or open circuits.
- ◆ Intermittent readings can also be caused by cold solder double check solder points if the heating element has recently been replaced.

To replace the heating element follow "*Replacing the heating element*" guide on the next page

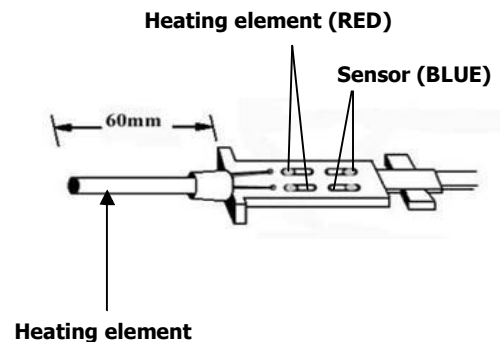

Note: Illustration shows diagram for 936A station, for the 936 station the sensor wire is blue and white with waxed coat.

REPLACING THE HEATING ELEMENT

The heating element can be replaced as follows:

1. Follow the steps in "disassembling the soldering iron".
2. Unsolder the heating element wires (RED) and the sensor wires (blue and/ or white).
3. The old heating element can now be detached from the hand piece board.
4. Detach the metal protector located at the bottom part of the heating element. (936 only)
5. Reattach the metal protector to the bottom part of the new heating element. (936 only)
6. Pass the New heating elements wires (RED) thru the holes located on top of the board.
7. Solder the heating element's wires and the sensor wires to the board match with the same colored wires (red wire to red wire on board, blue wire with blue wire on board etc.)

For 936A:

- ◆ Solder one RED wire of heating element with red wire on PCB.
- ◆ Solder the other RED wire of heating element with blue wire on PCB.
- ◆ Solder one BLUE wire of heating element with white wire on PCB.
- ◆ Solder the other BLUE wire of heating element with green wire on PCB

For 936:

- ◆ Solder one RED wire of heating element with RED wire on PCB.
- ◆ Solder the other RED wire of heating element with YELLOW wire on PCB.
- ◆ Solder BLUE wire of heating element with BLUE wire on PCB.
- ◆ Solder WHITE wire of heating element to with BLACK wire on PCB

TROUBLESHOOTING CONNECTIONS

The 5 pin socket can be tested to detect faults in the handpiece:

Before plugging in the hand piece conduct the following test:

Pins 4 & 2	∞
Pins 4 & 1	∞
Pins 5 & 1	∞
Pins 5 & 2	∞

If any of the above mentioned combination registers a short review the steps in "replacing the heating element" to ensure proper connections.

 **Warning:** Ensure none of the above mentioned conditions are present before plugging in the hand piece. Failure to do so can damage the internal circuitry of the unit.

Test the resistances of the following configurations:

For 936A:

Pins 1 & 2	2.3 to 3.5 Ω
Pins 4 & 5	43 to 58 Ω
Pin 3 & solder tip	Below 2 Ω



For 936:

Pins 1 & 2	19 to 23 Ω
Pins 4 & 5	1.2 to 1.5 Ω
Pin 3 & solder tip	Below 2 Ω