

USER'S MANUAL

BM315s BM319s Automotive Multimeter

BRYMEN[®]
BRIGHT PEOPLE'S CHOICE

1) SAFETY

Terms in this manual

- WARNING** identifies conditions and actions that could result in serious injury or even death to the user.
- CAUTION** identifies conditions and actions that could cause damage or malfunction in the instrument.

This manual contains information and warnings that must be followed for operating the instrument safely and maintaining the instrument in a safe operating condition. If the instrument is used in a manner not specified by the manufacturer, the protection provided by the instrument may be impaired. The meter is intended only for indoor use.

The meter protection rating, against the users, is double insulation per IEC/UL/EN61010-1 Ed. 3.0, IEC/EN61010-2-030 Ed. 1.0, IEC/EN61010-2-033 Ed. 1.0, IEC/UL/EN61010-031 Ed. 1.1 and CAN/CSA-C22.2 No. 61010-1-12 Ed. 3.0 to Category II 1000V, CAT III 600V and CAT IV 300V AC & DC.

Terminals (to COM) measurement category:

V / mA μ A / A : Category II 1000V, CAT III 600V and CAT IV 300V AC & DC.

Per IEC61010-1 2nd Ed. (2001) Measurement Category

Measurement Category II (CAT II) is for measurements performed on circuits directly connected to the low voltage installation. Examples are measurements on household appliances, portable tools and similar equipment.

WARNING

To reduce the risk of fire or electric shock, do not expose this product to rain or moisture. To avoid electrical shock hazard, observe the proper safety precautions when working with voltages above 60 VDC or 30 VAC rms. These voltage levels pose a potential shock hazard to the user. Do not touch test lead tips or the circuit being tested while power is applied to the circuit being measured. Keep your fingers behind the finger guards of the test leads during measurement. Inspect test leads, connectors, and probes for damaged insulation or exposed metal before using the instrument. If any defects are found, replace them immediately. Do not measure any current that exceeds the current rating of the protection fuse. Do not attempt a current measurement to any circuit where the open circuit voltage is above the protection fuse voltage rating. Suspected open circuit voltage should be checked with voltage functions. Never attempt a voltage measurement with the test lead inserted into the μ A/mA or A input jack. Only replace the blown fuse with the proper rating as specified in this manual.

CAUTION

Disconnect the test leads from the test points before changing functions. Always set the instrument to the highest range and work downward for an unknown value when using manual ranging mode.

INTERNATIONAL ELECTRICAL SYMBOLS

⚠	Caution ! Refer to the explanation in this Manual
⚡	Caution ! Risk of electric shock
⏚	Earth (Ground)
□	Double Insulation or Reinforced insulation
⏏	Fuse
~	AC--Alternating Current
---	DC--Direct Current

2) CENELEC DIRECTIVES

The instruments conform to CENELEC Low-voltage directive 2006/95/EC and Electromagnetic compatibility directive 2004/108/EC

3) PRODUCT DESCRIPTION

Note: Top of the line model is used as representative for illustration purposes. Please refer to your respective model for function availability.

1) 3-5/6 digits 6000 counts LCD display

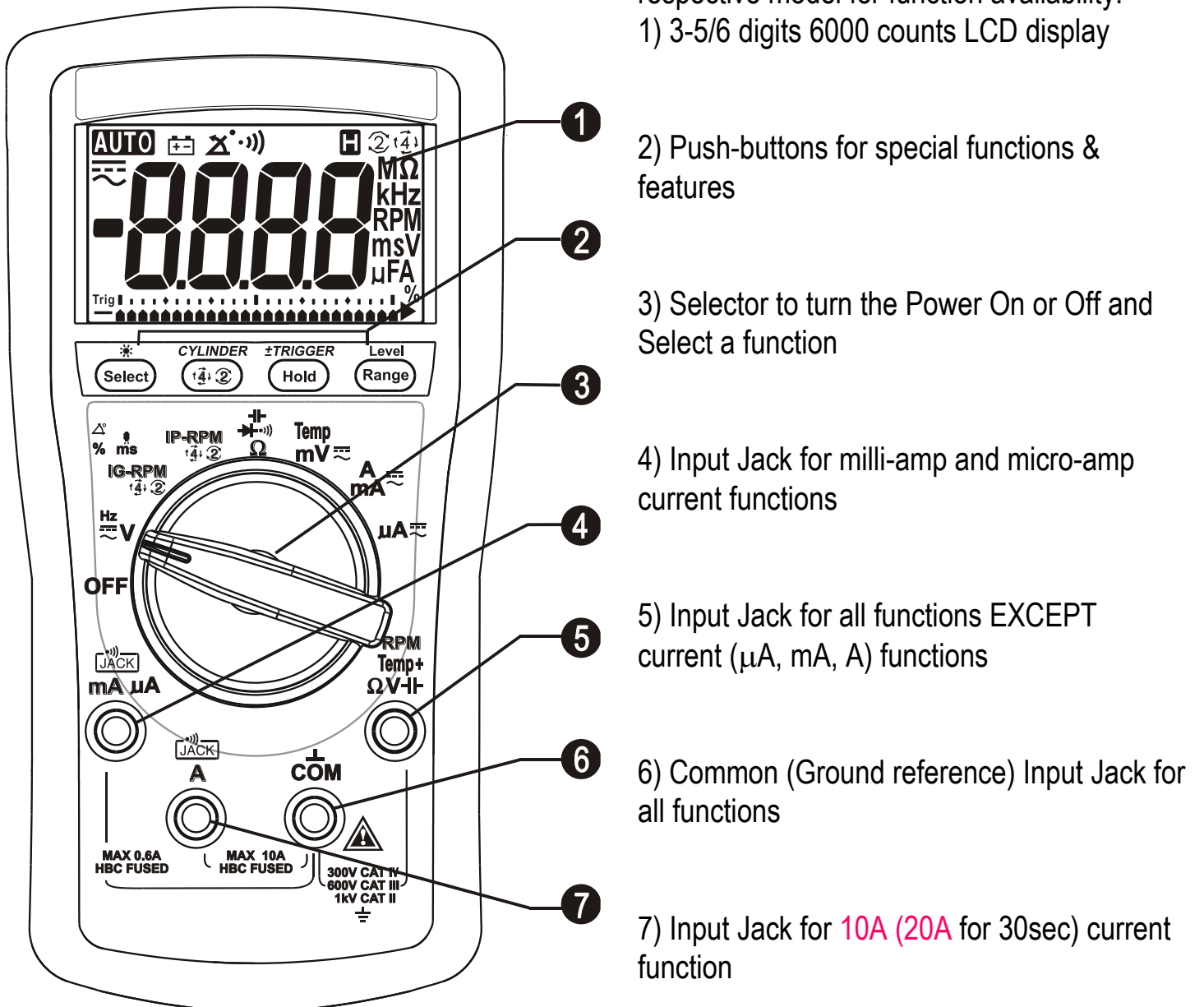

2) Push-buttons for special functions & features

3) Selector to turn the Power On or Off and Select a function

4) Input Jack for milli-amp and micro-amp current functions

5) Input Jack for all functions EXCEPT current (μA , mA, A) functions

6) Common (Ground reference) Input Jack for all functions

7) Input Jack for **10A** (**20A** for 30sec) current function

Analog bar-graph

The analog bar graph provides a visual indication of measurement like a traditional analog meter needle. It is excellent in detecting faulty contacts, identifying potentiometer clicks, and indicating signal spikes during adjustments.

Average sensing RMS calibrated

RMS (Root-Mean-Square) is the term used to describe the effective or equivalent DC value of an AC signal. Most digital multimeters use average sensing RMS calibrated technique to measure RMS values of AC signals. This technique is to obtain the average value by rectifying and filtering the AC signal. The average value is then scaled upward (calibrated) to read the RMS value of a sine wave. In measuring pure sinusoidal waveform, this technique is fast, accurate and cost effective. In measuring non-sinusoidal waveforms, however, significant errors can be introduced because of different scaling factors relating average to RMS values.

4) OPERATION

CAUTION

Before and after hazardous voltage measurements, test the voltage function on a known source such as line voltage to determine proper meter functioning.

DCV, ACV, & Line Frequency functions

Press the **SELECT** button momentarily to select the subject functions in sequence. Last selection will be saved as power up default for repeat measurement convenience.

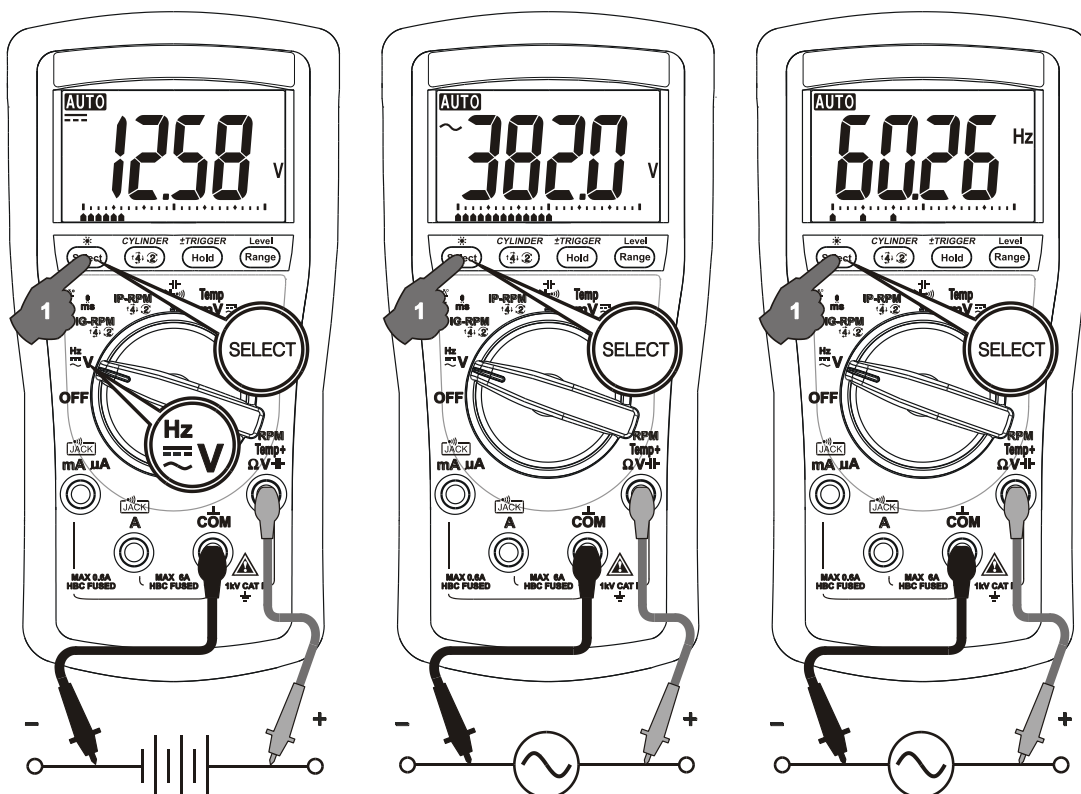

Note:

**Input sensitivity varies automatically with function range selected before activating the Hz*

function. 6V function range has the highest and the 1000V range has the lowest. It is recommended to first measure the signal voltage (or current) level then activate the Hz function in that voltage (or current) range to automatically set the most appropriate trigger level. You can also press the **Level (RANGE)** button momentarily to select another trigger level manually. If the Hz reading becomes unstable, select lower sensitivity to avoid electrical noise. If the reading shows zero, select higher sensitivity.

*Number of Bar-graph pointer is used to indicate input range (sensitivity) selected. 1/2/3/4 pointers indicate that 6/60/600/1000V is selected respectively

Ω Resistance, \rightarrow Continuity, \dashv Capacitance (Model 319s only), & \rightarrow Diode test functions
Press the **SELECT** button momentarily to select the subject functions in sequence. Last selection will be saved as power up default for repeat measurement convenience.

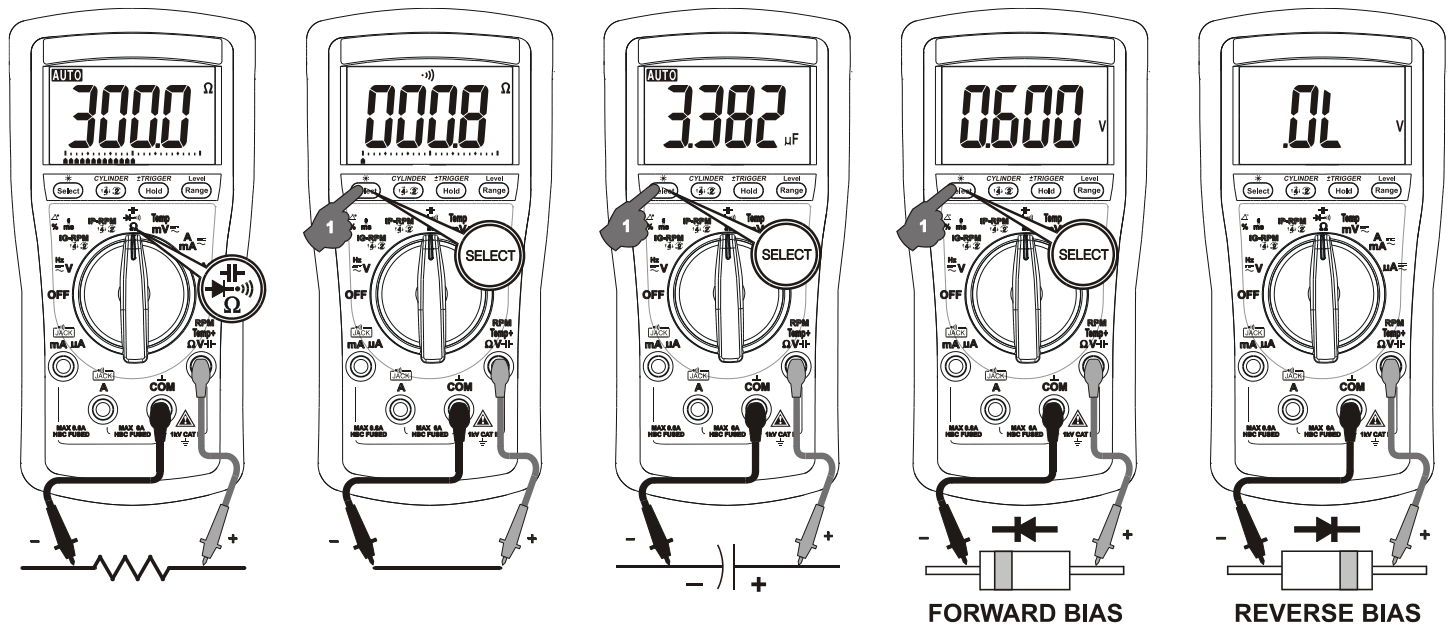

CAUTION

Discharge capacitors before making any measurement. Large value capacitors should be discharged through an appropriate resistance load.

CAUTION

Using resistance and continuity function in a live circuit will produce false results and may damage the instrument. In many cases the suspected component must be disconnected from the circuit to obtain an accurate reading

\rightarrow Continuity function is convenient for checking wiring connections and operation of switches. A continuous beep tone indicates a complete wire.

Normal forward voltage drop (forward biased) for a good silicon diode is between 0.400V to 0.900V. A reading higher than that indicates a leaky diode (defective). A zero reading indicates a

shorted diode (defective). An OL indicates an open diode (defective). Reverse the test leads connections (reverse biased) across the diode. The digital display shows OL if the diode is good. Any other readings indicate the diode is resistive or shorted (defective).

DCmV, ACmV & Temperature °C & °F functions (Model 319s only)

Press the **SELECT** button momentarily to select the subject functions in sequence. Last selection will be saved as power up default for repeat measurement convenience.

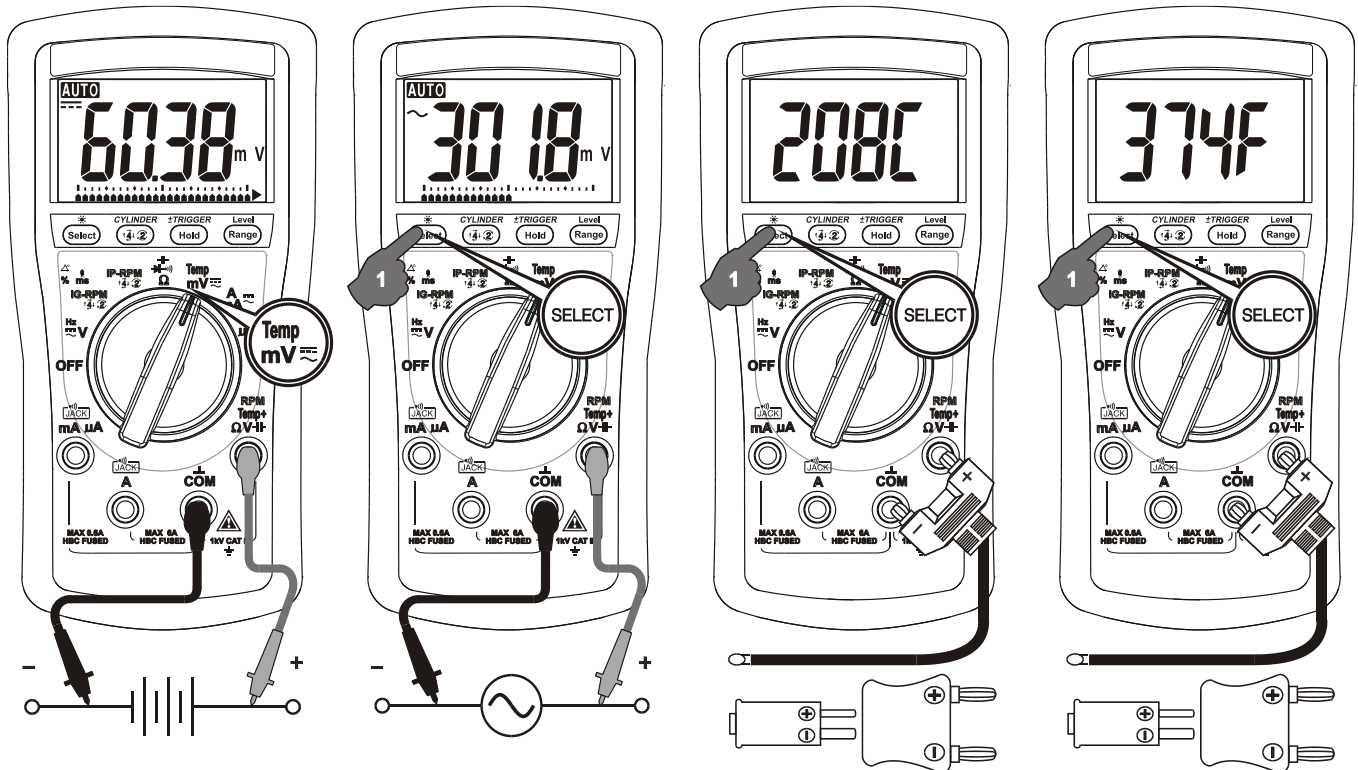

Note: Be sure to insert the banana plug K-type temperature bead probe Bkp60 with correct **+** **-** polarities. You can also use a plug adapter Bkb32 (Optional purchase) with banana pins to K-type socket to adapt other standard K type mini plug temperature probes.

μ A (Model 319s only), mA (Model 319s only) and A Current functions

Press **SELECT** button momentarily to toggle between DC and AC. Last selection will be saved as power up default for repeat measurement convenience.

*Note: When measuring a 3-phase system, special attention should be taken to the phase-to-phase voltage which is significantly higher than the phase-to-earth voltage. To avoid exceeding the voltage rating of the protection fuse(s) accidentally, always consider the phase-to-phase voltage as the working voltage for the protection fuse(s).

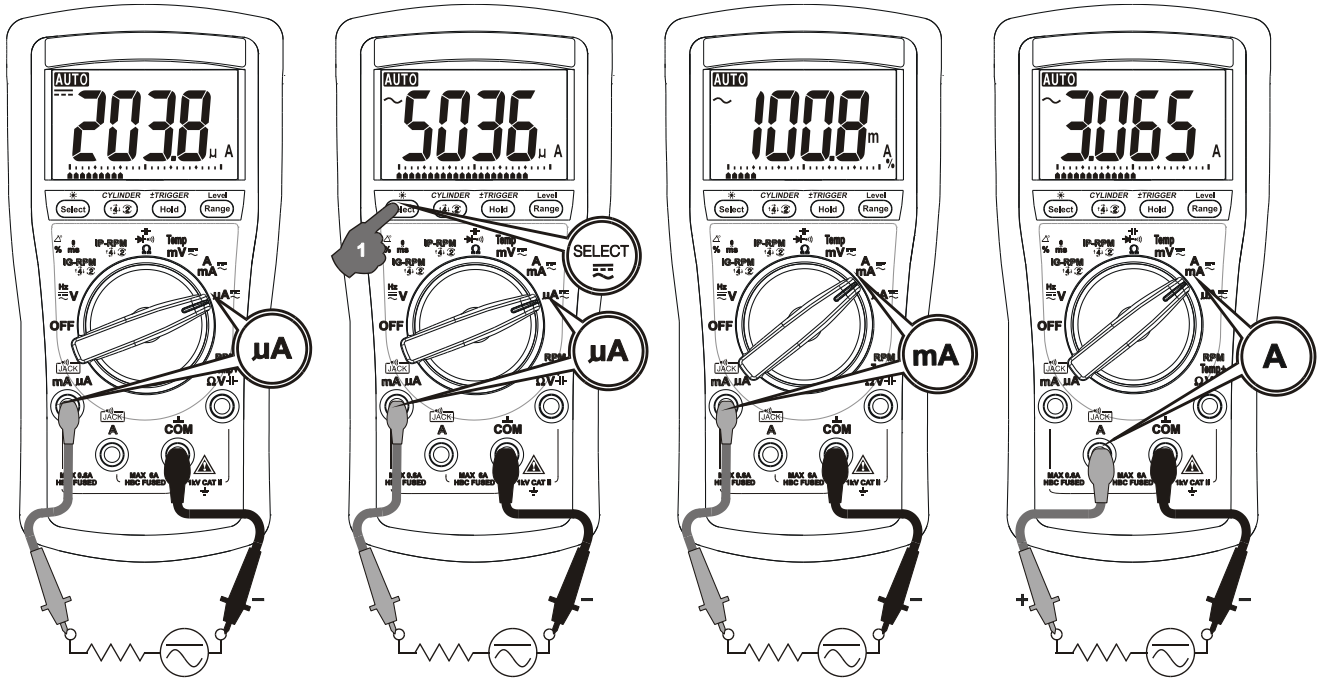

IG-RPM, DWELL Δ° , DUTY % & μ -ms functions

Press the **SELECT** button momentarily to select the subject functions in sequence. Last selection will be saved as power up default for repeat measurement convenience.

IG-RPM (4), (2) or (2)M function

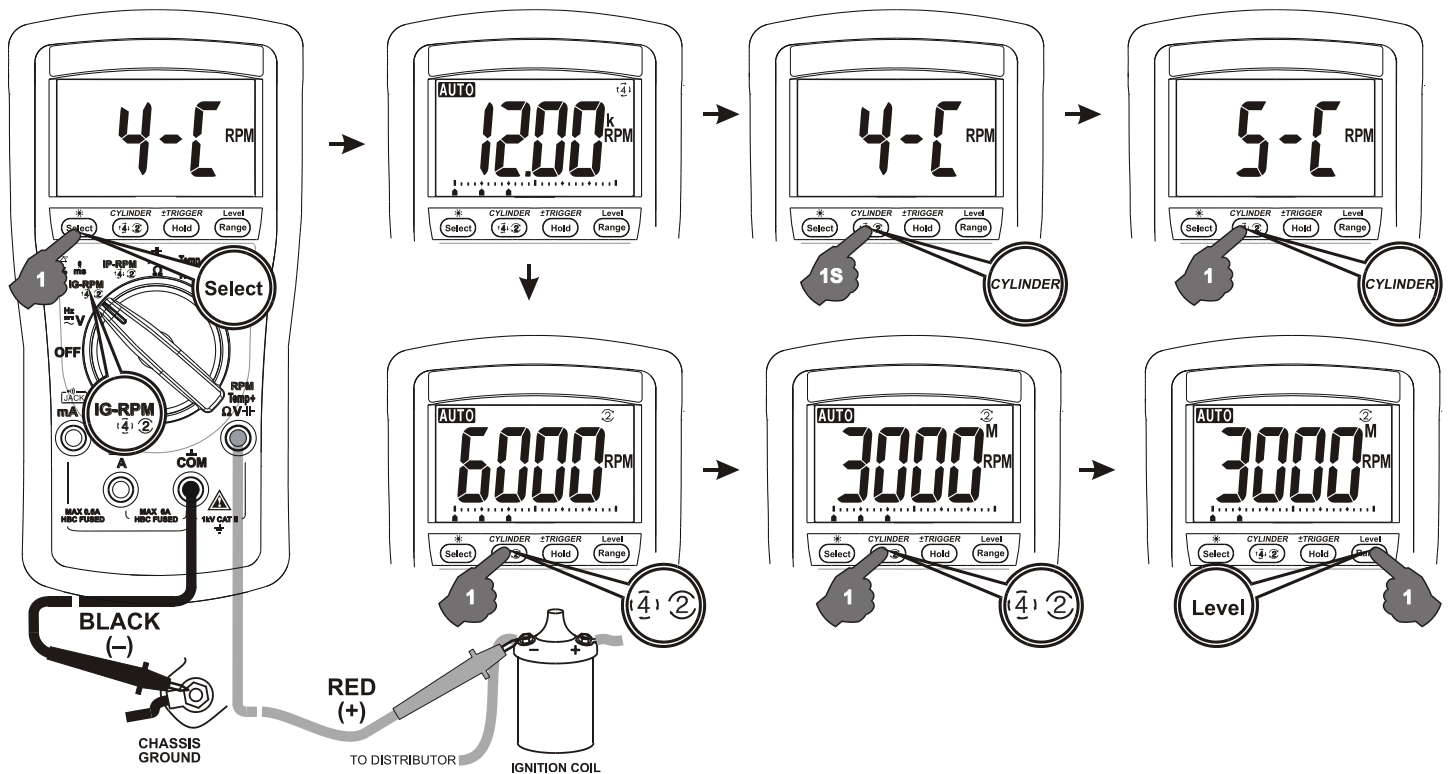

Press (4) (2) button momentarily to select through **RPM (4)** for 4-stroke, **RPM (2)** for 2-stroke and DIS, and **RPM (2) M** for special 2-stroke waste ignition engine

Number of cylinders defaults at 4 cylinders. Press **CYLINDER** button for one second or more to

display the cylinder setting and press momentarily again within one second to select the number of cylinders from 1 through 12 to match the engine under test

Trigger level defaults at 3. Press the **Level (RANGE)** button momentarily to select another trigger level. If the RPM reading becomes unstable, select lower sensitivity to avoid electrical noise. If the reading shows zero, select higher sensitivity. Number of Bar-graph pointer is used to indicate sensitivity selected.

Δ DWELL & %Duty functions

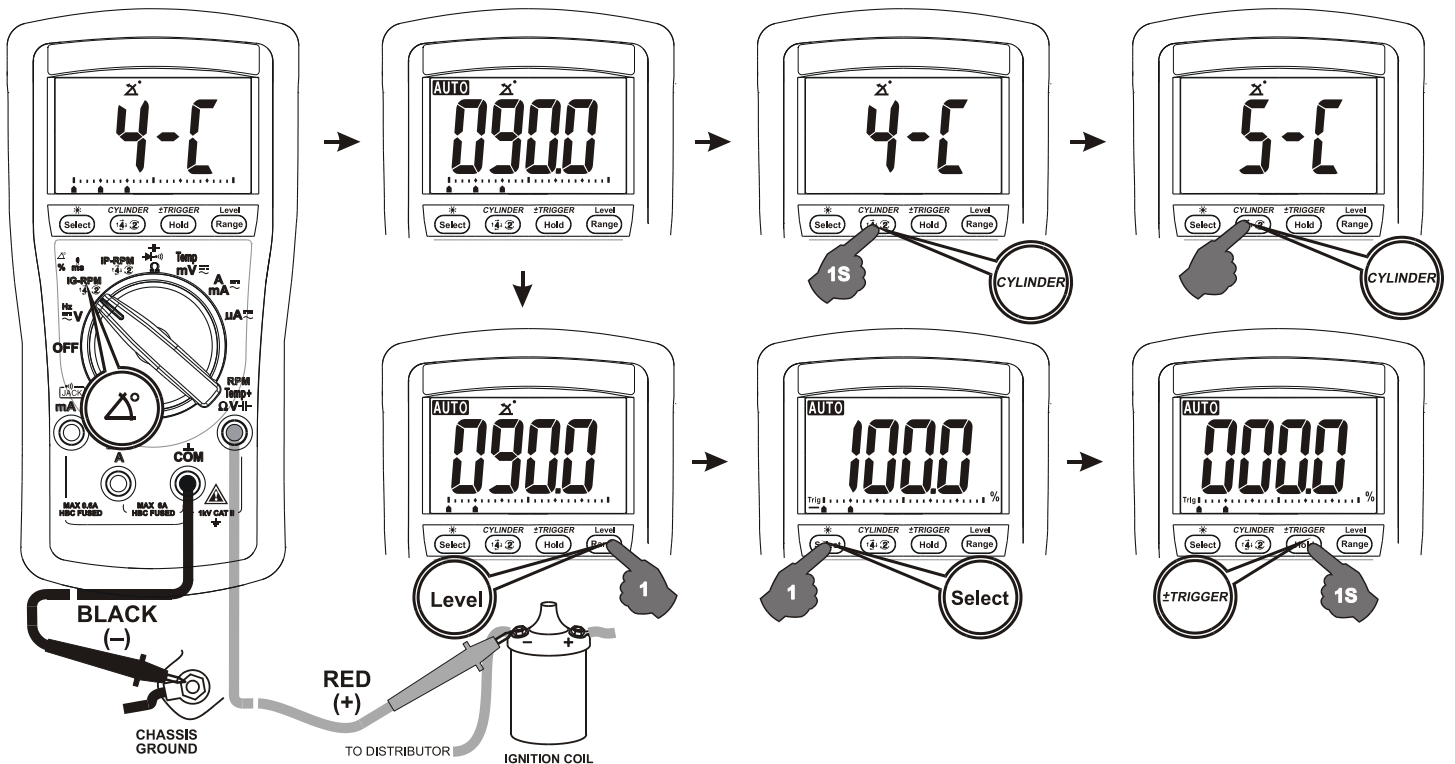

Number of cylinders defaults at 4 cylinders. Press **Cylinder** button for one second or more to display the cylinder setting, and press momentarily again within one second to select the number of cylinders from 1 through 12 to match the engine under test. Adjust the dwell angle according to the procedures outlined in your vehicle service manual. Re-check the timing whenever the dwell angle has been adjusted.

Press **SELECT** button momentarily to display DWELL reading in terms of percentage (%) if required. Positive & negative trigger slopes are selectable through pressing \pm **TRIGGER** button for one second or more in %Duty function for advanced applications.

Trigger level defaults at 3. Press the **Level (RANGE)** button momentarily to select another trigger level. If the Δ DWELL or %Duty reading becomes unstable, select lower sensitivity to avoid electrical noise. If the reading shows zero, select higher sensitivity. Number of Bar-graph pointer is used to indicate sensitivity selected.

ms FUEL INJECTION DETECTOR function

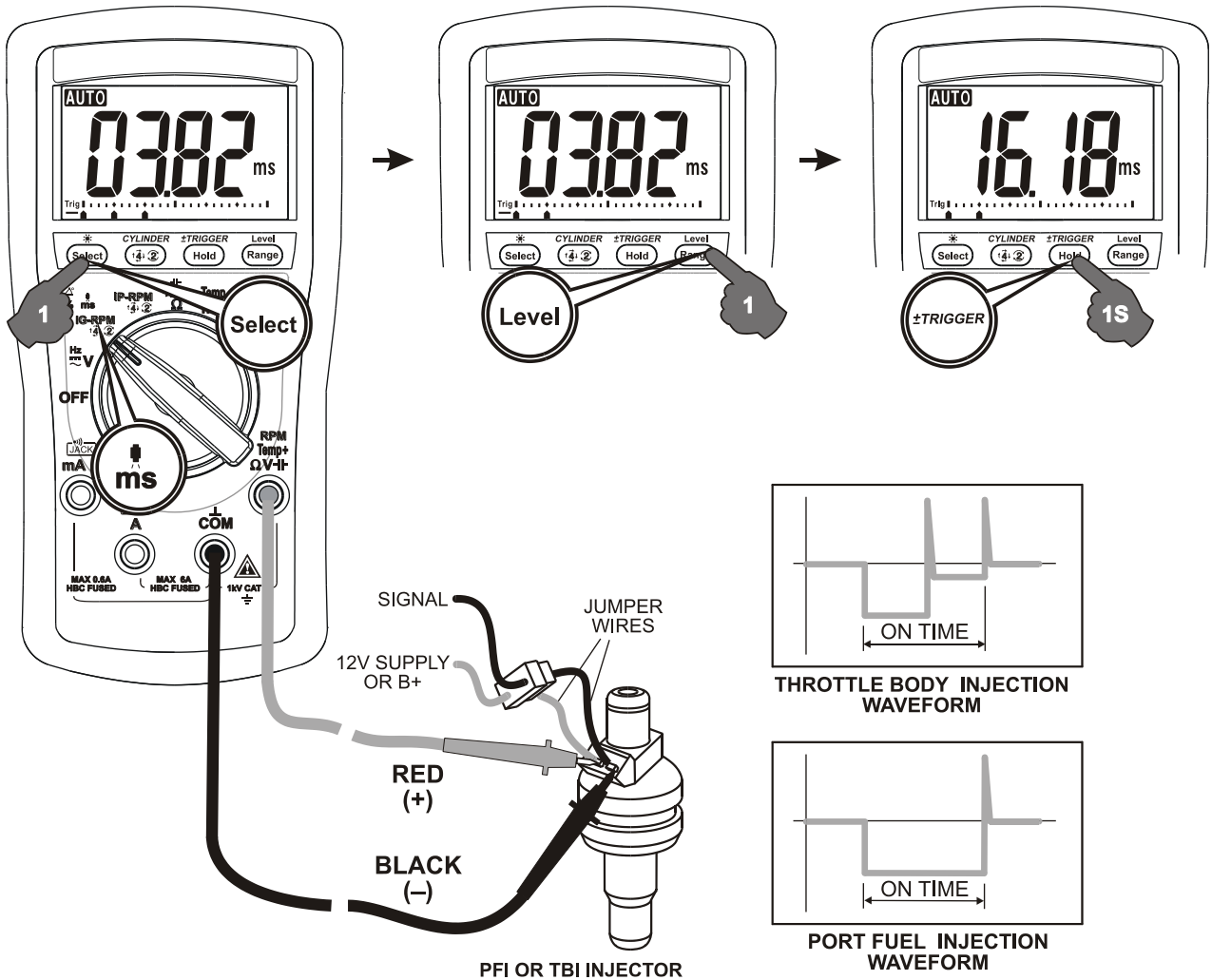

Trigger level defaults at 3. Press the **Level (RANGE)** button momentarily to select another trigger level. If the reading becomes unstable, select lower sensitivity to avoid electrical noise. If the reading shows zero, select higher sensitivity. Number of Bar-graph pointer is used to indicate sensitivity selected.

Positive & negative trigger slopes are selectable through pressing **± TRIGGER** button for one second or more.

Press **SELECT** button momentarily 3 times to display ms reading in terms of percentage (%) if required

Note: This ms function applies to both Port Fuel Injectors (PFI) which operate with a single on time pulse and Throttle Body Injectors (TBI) which operate with twin pulses

IP-RPM (4), (2) or (2)M function

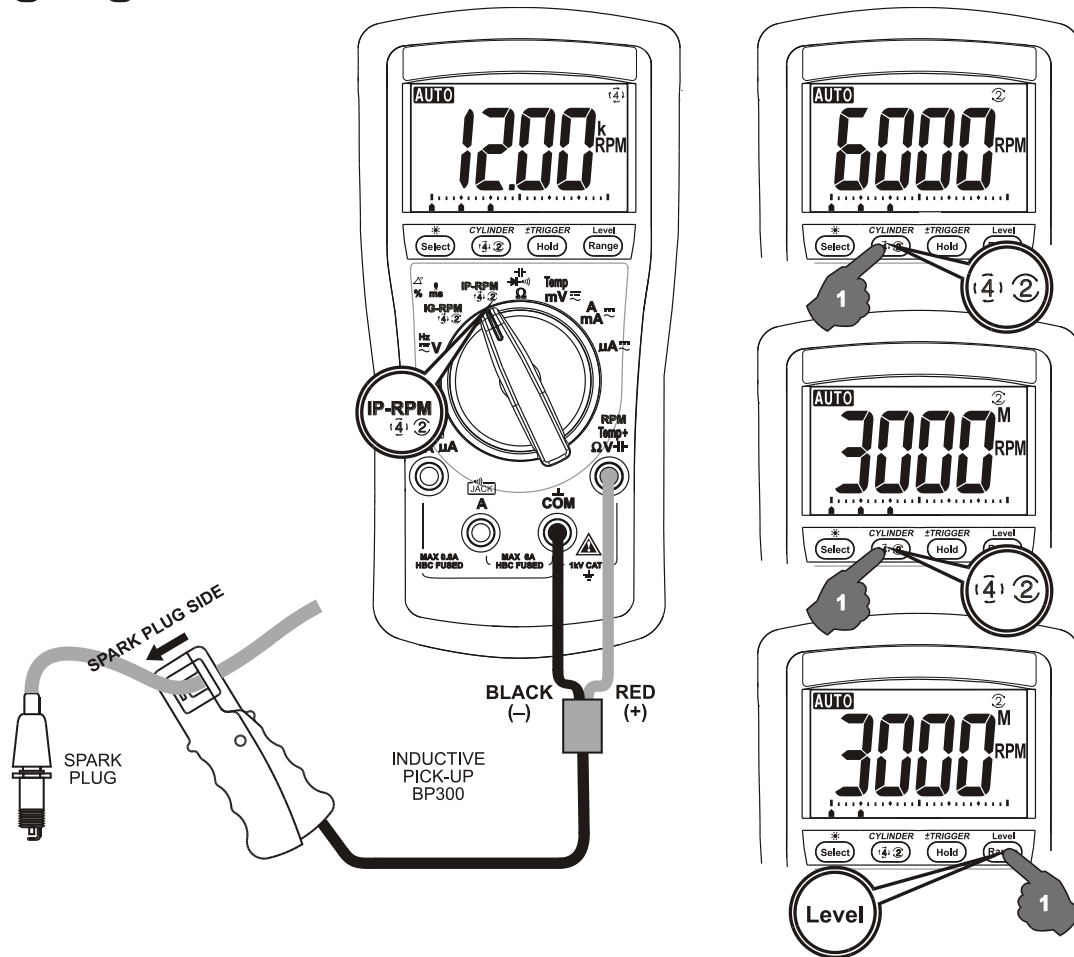

Press (4) (2) button momentarily to select through **RPM (4)** for 4-stroke, **RPM (2)** for 2-stroke and DIS, and **RPM (2) M** for special 2-stroke waste ignition engine

Trigger level defaults at 3. Press the **Level (RANGE)** button momentarily to select another trigger level. If the RPM reading becomes unstable, select lower sensitivity to avoid electrical noise. If the reading shows zero, select higher sensitivity. Number of Bar-graph pointer is used to indicate sensitivity selected.

Backlighting LCD display (Model 319s only)

Press the **SELECT** button for 1 second or more to toggle the LCD backlight. The backlight will also be turned off automatically after 32 seconds to extend battery life.

Hold

The hold feature freezes the display for later view. Press the **HOLD** button momentarily to toggle the hold feature.

Manual or Auto-ranging

Press the **RANGE** button momentarily to select manual-ranging, and the meter will remain in the range it was in, the LCD **AUTO** turns off. Press the button momentarily again to step through the ranges. Press and hold the button for 1 second or more to resume auto-ranging.

Note: Manual ranging feature is not available in **Hz**, **—|—**, **RPM**, **ms**, **DWELL & Duty** functions.

Set Beeper Off

Press the **RANGE** button while turning the meter on to temporarily disable the Beeper feature. Turn the rotary switch OFF and then back on to resume.

Beep-Jack™ Input Warning

The meter beeps as well as displays “**InEr**” to warn the user against possible damage to the meter due to improper connections to the μA , mA, or A input jacks when other function (like voltage function) is selected.

Auto-Power-Off (APO)

The Auto-Power-Off (APO) mode turns the meter off automatically to extend battery life after approximately 34 minutes of no rotary switch or push button operations. To wake up the meter from APO, press the **SELECT** button momentarily or turn the rotary switch OFF and then back on. Always turn the rotary switch to the OFF position when the meter is not in use

Disabling Auto-Power-Off

Press the **SELECT** button while turning the meter on to temporarily disable the Auto-Power-Off (APO) feature. Turn the rotary switch OFF and then back on to resume.

5) MAINTENANCE

WARNING

To avoid electrical shock, disconnect the meter from any circuit, remove the test leads from the input jacks and turn OFF the meter before opening the case. Do not operate with open case. Install only the same type of fuse or equivalent

Calibration

Periodic calibration at intervals of one year is recommended to maintain meter accuracy. Accuracy is specified for a period of one year after calibration. If self-diagnostic message “**C_Er**” is being displayed while powering on, some meter ranges might be largely out of specifications. To avoid mis-leading measurements, stop using the meter and send it for re-calibration. Refer to the LIMITED WARRANTY section for obtaining warranty or repairing service.

Cleaning and Storage

Periodically wipe the case with a damp cloth and mild detergent; do not use abrasives or solvents. If the meter is not to be used for periods of longer than 60 days, remove the battery and store it separately

Trouble Shooting

If the instrument fails to operate, check battery, fuses, leads, etc., and replace as necessary. Double check operating procedure as described in this user’s manual

If the instrument voltage-resistance input terminal has subjected to high voltage transient (caused by lightning or switching surge to the system) by accident or abnormal conditions of operation, the series fusible resistors will be blown off (become high impedance) like fuses to protect the user and the instrument. Most measuring functions through this terminal will then be open circuit. The series fusible resistors and the spark gaps should then be replaced by qualified technician. Refer to the LIMITED WARRANTY section for obtaining warranty or repairing service.

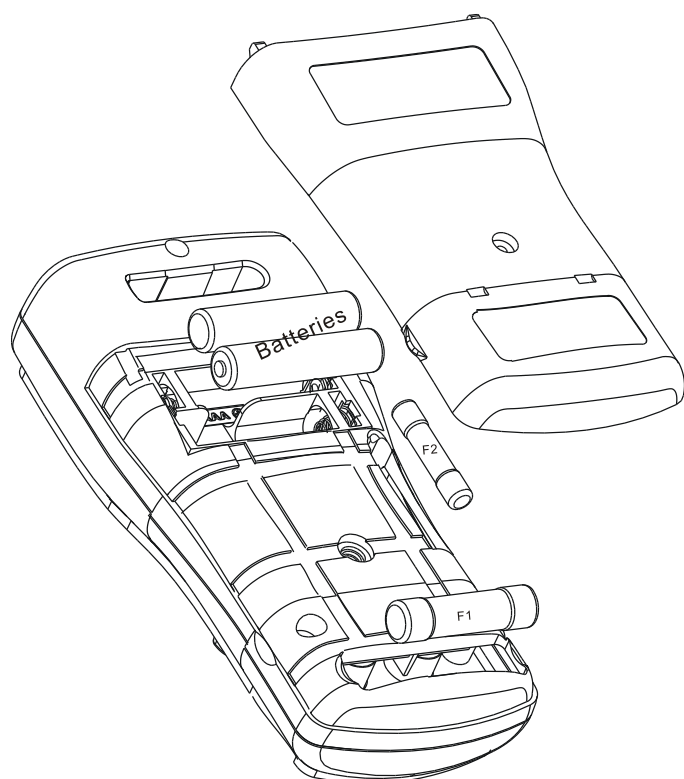

Battery and Fuse replacement

Battery use: 1.5V AAA Size battery x 2

Fuses use:

Fuse (F2) for μ mA current input:

0.4A/1000V ac & dc, IR 30kA, F fuse; Dimension:
6 x 32 mm

Fuse (F1) for A current input:

11A/1000V ac & dc, IR 20kA, F fuse; Dimension:
10 x 38 mm

Battery and Fuse replacement:

Loosen the screw from the access cover of the case bottom. Lift the access cover. Replace the batteries or fuse. Re-fasten the screw.

GENERAL SPECIFICATION

Display: 3-5/6 digits 6,000 counts

Update Rate: 5 per second nominal

24 Segments Bar graph: 40 per second max

Operating Temperature: 0°C to 40°C

Relative Humidity: Maximum relative humidity 80% for temperature up to 31°C decreasing linearly to 50% relative humidity at 40°C

Altitude: Operating below 2000m

Storage Temperature: -20°C ~ 60°C, < 80% R.H. (with battery removed)

Temperature Coefficient: Nominal 0.15 x (specified accuracy)/ °C @ (0°C ~ 18°C or 28°C ~ 40°C), or otherwise specified

Sensing: Average sensing

Pollution Degree: 2

Safety: Double insulation per IEC/UL/EN61010-1 Ed. 3.0, IEC/EN61010-2-030 Ed. 1.0, IEC/EN61010-2-033 Ed. 1.0, IEC/UL/EN61010-031 Ed. 1.1 and CAN/CSA-C22.2 No. 61010-1-12

Ed. 3.0 to Category II 1000V, **CAT III 600V and CAT IV 300V** AC & DC

Transient Protection: 6kV (1.2/50 μ s surge)

Terminals (to COM) Measurement Category:

V / mA μ A / A: Category II 1000V, CAT III 600V and CAT IV 300V AC & DC.

E.M.C. : Meets EN61326-1:2006 (EN55022, EN61000-3-2, EN61000-3-3, EN61000-4-2, EN61000-4-3, EN61000-4-4, , EN61000-4-5, EN61000-4-6, EN61000-4-8, EN61000-4-11)

In an RF field of 3V/m:

Capacitance function is not specified

Other function ranges:

Total Accuracy = Specified Accuracy + 100 digits

Performance above 3V/m is not specified

Overload Protection:

μ A & mA : 0.4A/1000V DC/AC rms, IR 30kA, F fuse

A : 11A/1000V DC/AC rms, IR 20kA, F fuse

V : 1100V DC/AC rms

mV, Ohm & others : 1000V DC/AC rms

Low Battery: Below approx. 2.3V

Power Supply: 1.5V AAA Size battery X 2

Power Consumption (typical): 4.3mA

APO Consumption (typical): 10 μ A

APO Timing: Idle for 34 minutes

Dimension: 161*80*50mm L*W*H (With Holster)

Weight: Approx. 340 gm (With Holster)

Special Features:

Backlighted LCD (Model **319s** only)

\pm Trigger: Selectable positive & negative trigger slopes

Cylinder: 9 Selectable number of cylinders (1, 2, 3, 4, 5, 6, 8, 10 & 12) in Dwell and IG-RPM functions

Hold: Freezes the display data for later view

Range: Manual & Auto-ranging selection

RPM (4): For RPM of traditional 4-stroke engines which have 1 ignition on every 4 engine strokes

RPM (2): For RPM of DIS & traditional 2-stroke engines which have 1 ignition on every 2 engine strokes

RPM (2)M: For RPM of 2-stroke waste ignition (on-board) engines which have 1 ignition on every single engine stroke

Accessories: Test lead pair; batteries installed; user's manual; BKP60 banana plug type-K thermocouple (Model **319s** only); BP300 Inductive pickup clip (Model **319s** only; **not certified by UL**)

Optional purchase accessories: Magnetic hanger BMH-01; BKB32 banana plug to type-K socket plug adaptor (Model **319s** only); BP300 Inductive pickup clip (Model **315s** only; **not certified by UL**)

Electrical Specification

Accuracy is given as +/- (% of reading digits + number of digits) or otherwise specified @ 23°C +/- 5°C and less than 75% R.H.

DC Voltage

RANGE	Accuracy
60.00mV	0.4%+3d
600.0mV	0.3%+3d
6.000V, 60.00V, 600.0V	0.4%+3d
1000V	0.7%+3d

Input Impedance: 10MΩ, 50 pF nominal

AC Voltage

RANGE	Accuracy
50Hz ~ 500Hz	
60.00mV, 600.0mV	2.0% + 5d
6.000V, 60.00V, 600.0V,	
1000V	2.2% + 5d

Input Impedance: 10MΩ, 50 pF nominal

Ohm

RANGE	Accuracy
600.0Ω,	0.5%+6d
6.000KΩ, 60.00KΩ	0.5%+3d
600.0KΩ	0.8%+4d
6.000MΩ	1.0%+5d
60.00MΩ	1.5%+5d

Open Circuit Voltage: 0.45VDC typical

Audible Continuity Tester

Audible Threshold: Between 10Ω and 200Ω

Response time: 32ms

Diode Tester

RANGE	Accuracy
1.000V	1.0% + 3d

Test Current: 0.50mA typically

Open Circuit Voltage: < 1.6VDC typically

Capacitance (Model 319s only)

RANGE	Accuracy
6.000μF,	2.0%+5d
60.00μF, 600.0μF	3.5%+5d
2000μF	4.0%+5d

Accuracies with film capacitor or better

DC Current

RANGE	Accuracy	Burden Voltage
600.0μA ¹⁾	0.7%+3d	0.25 mV/uA
6000μA ¹⁾	0.5%+3d	
60.00mA ¹⁾	0.7%+3d	2.5 mV/mA
600.0mA ¹⁾	0.5%+3d	
6.000A	0.7%+3d	0.03V/A
10.00A ²⁾	0.5%+3d	

¹⁾ Ranges for Model 319 only

²⁾ 10A continuous, >10A to 20A for 30 sec. max with 5 minutes cool down interval

AC Current

RANGE	Accuracy	Burden Voltage
50Hz ~ 500Hz		
600.0μA ¹⁾	2.2%+5d	0.25 mV/uA
6000μA ¹⁾	2.0%+5d	
60.00mA ¹⁾	2.2%+5d	2.5 mV/mA
600.0mA ¹⁾	2.0%+5d	
6.000A	2.2%+5d	0.03V/A
10.00A ²⁾	1.2%+5d	

¹⁾ Ranges for Model 319 only

²⁾ 10A continuous, >10A to 20A for 30 sec. max with 5 minutes cool down interval

Temperature (Model 319s only)

RANGE	Accuracy
-50 °C ~ 1000 °C	0.5% + 3d
-58 °F ~ 1832 °F	0.5% + 6d

K type thermocouple range & accuracy not included

IP-RPM* (Inductive pickup type)

	RANGE	Accuracy
RPM 4	240 -20000 RPM	2 RPM
RPM 2	120 -10000 RPM	2 RPM
RPM 2M	60 -5000 RPM	2 RPM

*Measurements via inductive pickup clip (optional purchase for Model 315s)

Four selectable trigger levels,

Sensitivity:

Level 1: 3.0V typically

Level 2: 4.5V typically

Level 3: 6.1V typically

Level 4: 8.1V typically

IG-RPM* (Contact signal type)

	RANGE	Accuracy
RPM 4	60 -20000 RPM	2 RPM
RPM 2	30 -10000 RPM	2 RPM
RPM 2M	15 -5000 RPM	2 RPM

*Measurements via test leads on Dwell, Fuel injection-ms and ignition primary signals

Nine selectable Cylinders: 1, 2, 3, 4, 5, 6, 8, 10 & 12

Four selectable trigger levels,

Sensitivity:

Level 1: 0.8V typically

Level 2: 1.85V typically

Level 3: 3.75V typically

Level 4: 6V typically

DWELL

RANGE	Accuracy
0.0° ~ 360.0° *	1.2° /krpm+1d
0.0%~100.0%	0.04%/krpm/cyl+2d

Specified ranges depend on engine rpm and number of Cylinders (cyl)

*Nine selectable Cylinders: 1, 2, 3, 4, 5, 6, 8, 10 & 12

Four selectable trigger levels,

Sensitivity:

Level 1: 0.8V typically

Level 2: 1.85V typically

Level 3: 3.75V typically

Level 4: 6V typically

Fuel injection-ms detector

RANGE *	Accuracy
PFI / Multi Point Injection	
0.05ms ~ 250.0ms	0.05ms+1d
0.0%~100.0%	0.04%/krpm +2d
TBI / Single Point Injection	
0.05ms ~ 250.0ms	0.05ms+1d
0.0%~100.0%	0.04%/krpm/cyl +2d

*Specified range depends on engine rpm

Selectable ± trigger slopes

Four selectable trigger levels,

Sensitivity:

Level 1: 0.8V typically

Level 2: 1.85V typically

Level 3: 3.75V typically

Level 4: 6V typically

Hz (Line-level) @ ACV & DCV

Function	Sensitivity (Sine RMS)	Range
6V	0.5V	10Hz - 10kHz
60V	5V	10Hz - 50kHz
600V	50V	10Hz - 50kHz
1000V	500V	45Hz - 1kHz

Accuracy: 0.1%+3d

LIMITED WARRANTY

BRYMEN warrants to the original product purchaser that each product it manufactures will be free from defects in material and workmanship under normal use and service within a period of one year from the date of purchase. BRYMEN's warranty does not apply to accessories, fuses, fusible resistors, spark gaps, batteries or any product which, in BRYMEN's opinion, has been misused, altered, neglected, or damaged by accident or abnormal conditions of operation or handling.

To obtain warranty service, contact your nearest BRYMEN authorized agent or send the product, with proof of purchase and description of the difficulty, postage and insurance prepaid, to BRYMEN TECHNOLOGY CORPORATION. BRYMEN assumes no risk for damage in transit. BRYMEN will, at its option, repair or replace the defective product free of charge. However, if BRYMEN determines that the failure was caused by misused, altered, neglected, or damaged by accident or abnormal conditions of operation or handling, you will be billed for the repair.

THIS WARRANTY IS EXCLUSIVE AND IS IN LIEU OF ALL OTHER WARRANTIES, EXPRESSED OR IMPLIED, INCLUDING BUT NOT LIMITED TO ANY IMPLIED WARRANTY OR MERCHANTABILITY OR FITNESS FOR A PARTICULAR PURPOSE OR USE. BRYMEN WILL NOT BE LIABLE FOR ANY SPECIAL, INDIRECT, INCIDENTAL OR CONSEQUENTIAL DAMAGES.



BRYMEN TECHNOLOGY CORPORATION

TEL:+886 2 2226 3396

FAX:+886 2 2225 0025

<http://www.brymen.com>



PRINTED ON RECYCLABLE PAPER, PLEASE RECYCLE

COPYRIGHT © MMXIII BTC, ALL RIGHTS RESERVED

P/N: 7M1C-1331-0000

PRINTED IN TAIWAN