DIGITAL POWER METER

MPM-1010/1010B

User Manual

MATRIX TECHNOLOGY INC.

Tel: +86-0755-28364276

Chapter I

MPM-1010/1010BDIGITAL POWER METER is a multifunctional measurement instrument integrating voltage test, current test, power test and power factor test. As an intelligent electrotechnical instrument, it adopts the high-speed processor inside and is widely applied in the production line, lab and quality control department of the manufacturing enterprises in fields i.e. lighting electrical appliance, power tool, domestic appliance, electrical machinery and electric heater.

MPM-1010/1010BDIGITAL POWER METER has the following features:

1. Digital display, visualized reading;
 2. The four windows displaying the true-value voltage, true-value current, peak current, power, power factor, frequency at the same time, fast testing;
 3. Automatic switching of voltage and current range to improve the measurement accuracy;
 4. Measurement accuracy uninfluenced by the wave shape;
 5. High reliability, long service time;
 - *6. Setting the upper and lower limits of parameter, having the qualified alarm function.
- The batch inspection to improve the efficiency;

Chapter II Fundamental Principles

The fundamental principles are as shown in Fig.1:

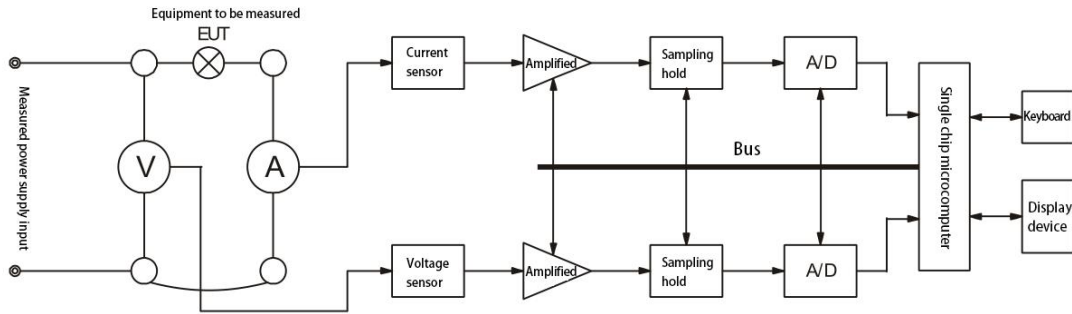

Equipment to be measured

Current sensor

Amplified

Sampling hold

A/D

Keyboard

Bus

Single chip microcomputer

Measured power supply input

Voltage sensor

Display device

Fig. 1 Diagram of Fundamental Principles

As shown in Fig.1, the instrument is composed of the analog part and the digital part. The analog part is mainly composed of circuits i.e. sensor, program-controlled amplifier, sampling holder and A/D. the digital part is composed of microcomputer, data accumulator and display device.

After passing the voltage sensor, the measured voltage signal will be decreased to the weak voltage. According to the signal size, it will be controlled by the microcomputer for range programmable gain; through the sampling holder, the voltage can be transformed into the digital signal by the analog/digital transformer A/D; the digital signal will be transmitted into the microcomputer to calculate the true-value of voltage (U_{RMS}) and output the value to the display device.

After passing the current sensor, the measured current signal will be decreased to the weak current signal, just like the measured voltage, after the process of programmable gain, sampling hold and A/D transformation, the true-value of current (I_{RMS}) and current peak (I_p) will be calculated and displayed in the microcomputer.

The true-value of voltage (U_{RMS}), true-value of current (I_{RMS}), active power (P) and power factor (PF) peak shall be measured according to the following formulas:

$$U_{RMS} = \sqrt{\frac{1}{N} \sum_{i=1}^N (U_i)^2}$$

$$I_{RMS} = \sqrt{\frac{1}{N} \sum_{i=1}^N (I_i)^2}$$

$$P = \frac{1}{N} \sum_{i=1}^N U_i \times I_i$$

$$PF = \frac{P}{U_{RMS} \times I_{RMS}}$$

N in the above formula is the point number of samples within the cycle (the cycle is determined by the frequency of measured signal); U_i and I_i are the values at some sampling moments.

Chapter III Specifications

I. Measuring range and intrinsic error

MPM-1010/1010B Model

Measurement item	Measurement range	Intrinsic error
True-value of voltage	1.00V-300.0V (automatic range)	$\pm(0.4\% \text{ reading} + 0.1\% \text{ range} + 3 \text{ words})$
True-value of current	0.001A-10 A (automatic range)	$\pm(0.4\% \text{ reading} + 0.1\% \text{ range} + 3 \text{ words})$
Peak current	0.001 A -12 A (automatic range)	$\pm(0.4\% \text{ reading} + 0.1\% \text{ range} + 3 \text{ words})$
Power	0.01W-3000W	$\pm(0.4\% \text{ reading} + 0.1\% \text{ range} + 3 \text{ words})$
Power factor	0.000-1.000	$\pm(0.004 + 0.001/\text{reading} + 3 \text{ words})$
Frequency	16Hz-650Hz	$\pm 0.5\text{Hz}$

II. Power supply requirements of Instrument

Voltage of power supply: 230V \pm 10%

Power frequency: 45Hz~65Hz

Maximum power: 15VA

III. External dimensions: W \times H \times D =220mm \times 100mm \times 365mm (IV-1003: W \times H \times D =220mm \times 100mm \times 300mm)

Instrument weight: about 2.5kg (IV-1003 about 2.2kg)

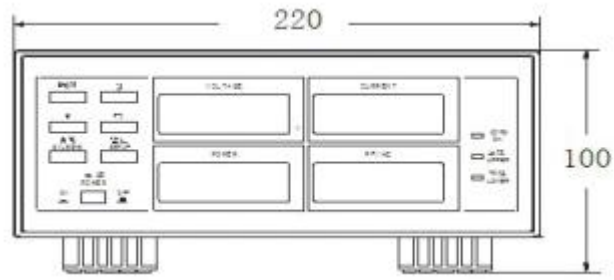

Fig. 2 External View (1001, 1002, 1003)

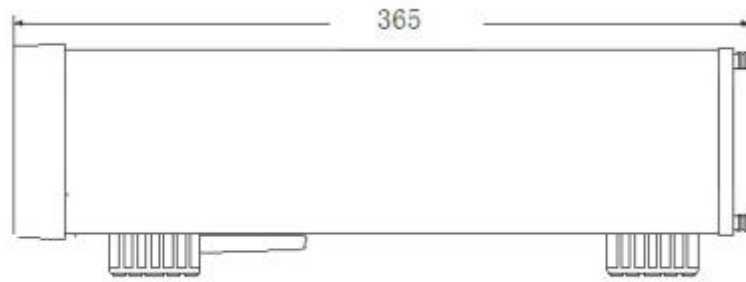

Fig. 2 External View (1001, 1002)

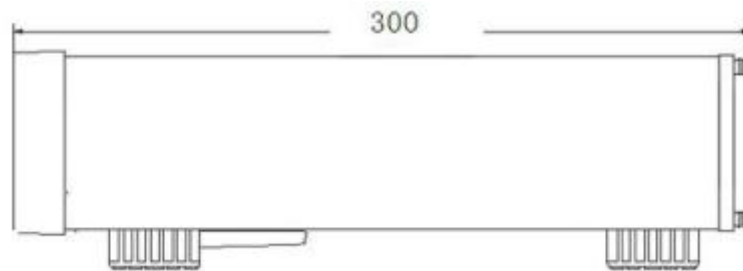

Fig.2 External View (1003)

Chapter IV Operation Instruction

I. The front panel is as shown in Fig.3:



Fig. 3 Front Panel

II. The back panel is as shown in Fig.4:



Fig. 4 Back panel

III. Measurement and wiring method

The measurement wiring is seen in “Fig.4 Back panel”.

1. The power socket labelled with “AC SOURCE” on the left side is the power inlet socket of the measured object (power source required by the measured load, for instance, the measured load is efficient lightbulb that requires the power of 120V, the 120V voltage shall be input here)

2. The white universal charge socket labelled with “LOAD” in the middle is the power outlet socket of the measured object (power source required by the measured load will be output here). When there are high-frequency components inside the measured voltage or current, or the heavy current is measured, it should be noted that the possible mutual interference and noise will influence the measurement accuracy.

Attention: according to the working current of the measured piece during the wiring, wire strong enough shall be adopted in case of dangers caused by excessive wire resistance, additive measurement error and possible wiring heating. The wire shall be as short as possible and kept as far away from the instrument shell as possible.

3. The left power socket is the power socket of the instrument (power supplied for the instrument work, what below the power socket of the instrument are the voltage input selection switch and 232 interface to connect computers in turn).

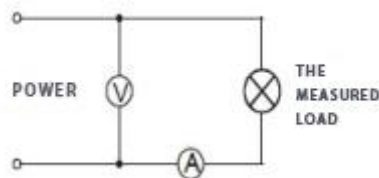

Power
the measured load

Fig. 5 Measurement Principle

IV. Power-on measurement

The power socket of the back panel shall be connected under the specified supply voltage. The power socket shall be equipped with earth wire.

After inspecting the wiring correctly, the instrument switch on the front panel shall be turned on, so that the instrument enters the measurement state. Power the load on and the required measurement value will be read on the display device of the front panel after the load works stably.

Attention: the instrument shall enter the stable state after being heated up for 15 minutes; there must be more than 10 seconds before it is powered on after the instrument is powered off. It is strictly forbidden to turn the switch on and off repeatedly within short time, otherwise the instrument service life will be shortened and there might be instrument failures. After the measurement in the current day, the instrument shall be powered off and the socket shall be pulled out to prevent the instrument damages caused by the possible lightning stroke.

V. Sorting function

During the finished product inspection on the production line, a large number of finished products with the same specifications are always tested to judge the quality of this batch. To improve the test efficiency, a certain range can be set inside the instrument to judge whether the products are qualified or not, so that the operating staff needn't to read or judge, which has reduced the workload of the operating staff and greatly improved the test efficiency. This is called the sorting function of the instrument.

To get the correct sorting results, the instrument must be set with the correct parameters.

Attention: products from different batches might have the different qualification judgment parameters; hence the instrument must be re-set.

This instrument is capable of setting the upper and lower limits of the tested current, power and PF value. In the sorting test, the tested pieces are qualified if the test values of current, power or PE value are smaller than the set upper limits and larger than the set lower limits; also, the tested pieces are qualified when the "qualified" light on the instrument panel is on.

The tested pieces are unqualified when the test values of current or power of are larger than the set upper limits or smaller than the set lower limits; the "qualified" light is off and the buzzer alarms to remind the operators.

If the operators don't want to hear the buzzer alarm, they can press the "sound proof" key; after which, the buzzer will not alarm but the "qualified" indicator will be normally on if the tested data are qualified.

1. About the functional keys

"SETUP" key: when the key is pressed for the first time, the instrument will enter the setup state from the measurement state; afterwards, a set parameter will be confirmed by each press while the instrument will continue to set the next parameter. The instrument will automatically withdraw from the setting state and return to the measurement state if the key is pressed again after all parameters are set.

"↑ /LOCK" key: being pressed at the setting state, data of the flicker bit will cyclically change as 0→1→2→3→···→9→0; being pressed at the standby state, instrument will be locked or unlocked!

“→” key: being pressed at the setting state, the data flicker bit will be right shifted for one bit, the four bits will cycle in turn.

“.” Key: being pressed at the setting state, the decimal place will be right shifted for one bit and cycles in return.

“Apk/ Hz/PF” key: being pressed at the measurement state, the lower right window of display device will cyclically shift and display between “current”, “frequency” and “power factor”.

“Sound proof” key: being pressed at the measurement state, the buzzer alarm will expire, if the sorting result is qualified, the buzzer will not alarm; being pressed again, the buzzer will work again; if the sorting result is qualified, the buzzer will give a hint.

2. Sorting setting procedures:

- First of all, the ultimate parameters of the product to be measured shall be determined.

- Press the “setting” key, the instrument will enter the setting state. The upper limited parameters of current will be displayed on the current window and data of the first bit will flicker; the “upper limit” indicator is on to indicate the upper limit parameters state of current being set. Press the “↑” key to change the data of flicker bit to the number to be set; press the “→” key to change the flicker bit, amend data of this bit and set the data of the four bits completely in turn before pressing the “.” key to change the decimal place setting. After setting the upper limit value of the current correctly and pressing the “setting” key for confirmation, the instrument will save the upper limit value of current and enter the state of setting the lower limit value of the current.

- Set the lower limit parameters state of the instrument, the lower limit parameters of current will be displayed on the current window; data of the first bit will flicker and the lower limit indicator will be on. The required parameters will be regulated by pressing the “↑”, “→” and “.” key; press the “setting” key for confirmation, the instrument will save the lower limit value of current and enter the state of setting the upper limit value of power.

- Set the upper limit parameters state of the instrument, the upper limit parameters will be displayed on the power window; data of the first bit will flicker and the upper limit indicator will be on. The required parameters will be regulated by pressing the “↑”, “→” and “.” key; press the “setting” key for confirmation, the instrument will save the upper limit value of power and enter the state of setting the lower limit value of power.

- Set the lower limit parameters state of the instrument, the lower limit parameters of power will be displayed on the power window; data of the first bit will flicker and the lower limit indicator will be on. The required parameters will be regulated by pressing the “↑”, “→” and “.” key; press the “setting” key for confirmation, the instrument will save the lower limit value of power and enter the state of setting the upper limit value of PF value.

- Set the upper limit parameters state of PF value of the instrument, the upper limit parameters of power will be displayed on the power window; data of the first bit will flicker and the upper limit indicator will be on. The required parameters will be regulated by pressing the “↑”, “→” and “.” key; press the “setting” key for confirmation, the instrument will save the upper limit value of power and enter the state of setting the lower limit value of PF value.

- Set the lower limit parameters state of PF value of the instrument, the lower limit parameters of power will be displayed on the power window; data of the first bit will flicker and the upper limit indicator will be on. The required parameters will be regulated by pressing the “↑”,

“→” and “.” key; press the “setting” key for confirmation, the instrument will save the lower limit value of power and automatically withdraw from the state of setting the upper and lower limit values.

- After being set, the data will be saved by the instrument; the data won't be lost when the instrument is powered on again after being disconnected; unless being re-set, the data won't be changed and can be saved permanently.

Chapter V Operating environment and Guarantee

I. Operating environment

1. Normal working conditions:

Temperature: (0~40) °C

Relative humidity: ≤80%

2. Power source

Voltage: 198V~242V

Frequency: 45Hz~65Hz

Attention: It is strictly forbidden to use this instrument at places with combustibles and explosives. Otherwise, any electric apparatus or electronic instrument being used in such environment might result in the safety injuries.

Warranty Card

What the warranty covered:

If the machine break down due to its defectiveness, MATRIX will provide free maintenance during warranty period. If the machine break down due to wrong operation or carelessness, then Matrix provide paid service within warranty period.

How long does this warranty last:

This warranty lasts for 3 years from the date of original purchase of all MATRIX branded products.

Who is covered:

This warranty covers only the original purchaser of this product. This warranty is not transferable to subsequent owners or purchasers of this product.

What do customers need to do to get repairs/service under the warranty policy?

If the machine get problem, please contact our local distributor. If you cannot find the local distributor, you can contact us directly, our email is service@szmatrix.com, our telephone No. is 0086 755 2836 4276.

What information do customers need to supply?

Model No.	
Serial No.	
Problem description	
Picture	
Video if necessary	